



Condensate Pump

Please read and save these instructions. Read carefully before attempting to assemble, install, operate or maintain the product described. Protect yourself and others by observing all safety information. Failure to comply with instructions could result in personal injury and/or property damage! Retain instructions for future reference.

Operating Instructions and Parts Manual

WCP85

SPECIFICATIONS	
POWER SUPPLY REQUIREMENTS	120 V, 60 Hz
MOTOR	Synchronous Type
CIRCUIT REQUIREMENT	15 A (minimum)
LIQUID TEMPERATURE RANGE	40° F- 120° F
TANK SIZE	2 Quarts

CONSTRUCTION	
MOTOR HOUSING	Thermoplastic
MOTOR SHAFT	Stainless Steel
IMPELLER	Thermoplastic
VOLUTE	Thermoplastic
PUMP DISCHARGE	3/8 in. Hose Barb

PERFORMANCE		
Model	Discharge Head	Max Flow
WCP85	Gal/hr	85

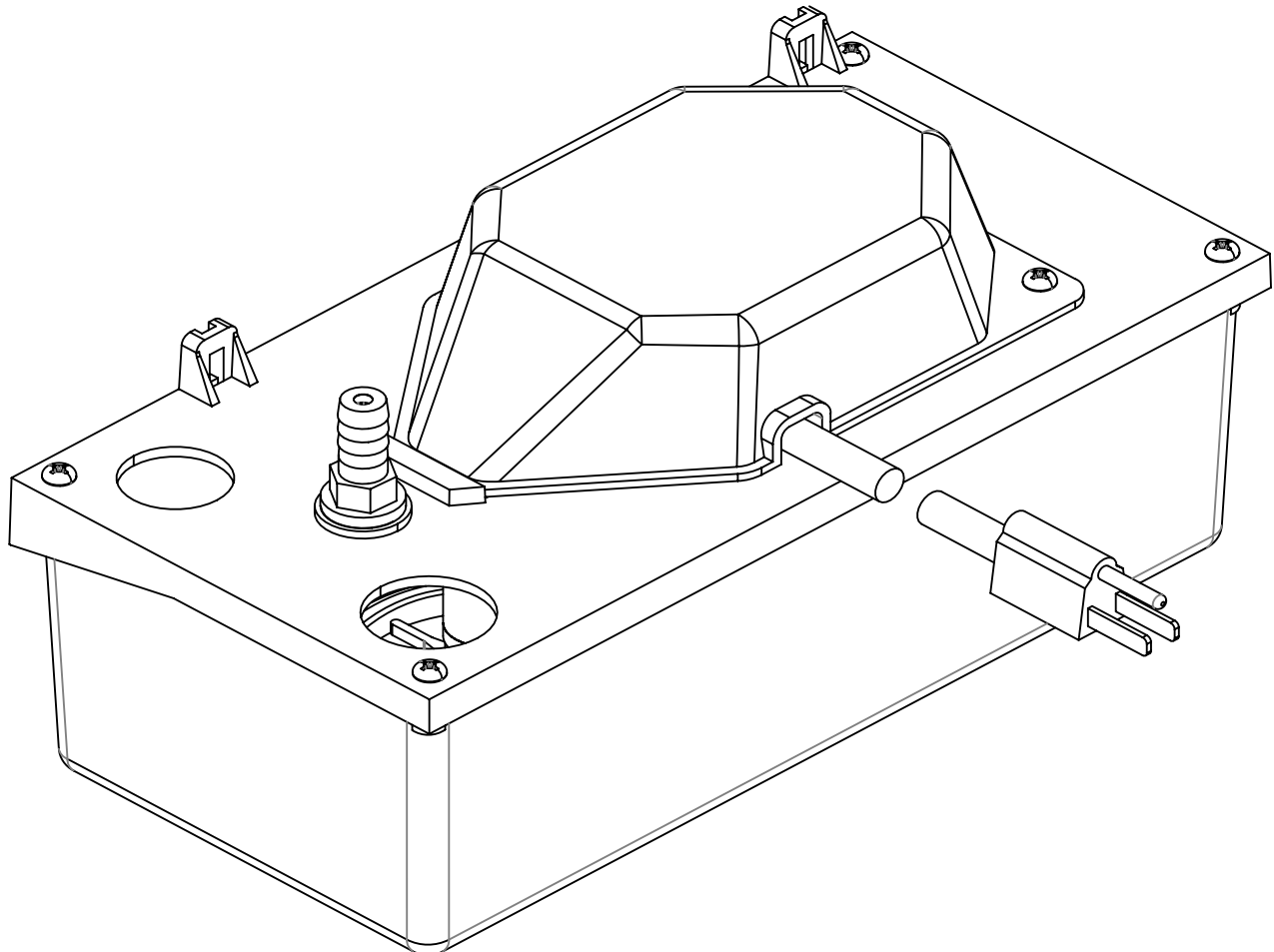

Intended for Indoor Use Only

Operating Instructions and Parts Manual

DESCRIPTION

A condensate unit removes condensation from air conditioning and high efficiency furnaces. The compact design of the unit consists of a 3/8" ID discharge and 6 ft. long power cord. The unit also contains a safety switch to automatically shut off HVAC equipment in the event of a failure (Additional wiring required). Intended for indoor use only.

UNPACKING

Inspect this unit before it is used. Occasionally, products are damaged during shipment. If the pump or components are damaged, return the unit to the place of purchase for replacement, or call Customer Support (800-237-0987).

SAFETY SIGNAL WORDS

This manual contains information that is very important to know and understand. This information is provided for **SAFETY** and to **PREVENT EQUIPMENT PROBLEMS**. To help recognize this information, observe the following symbols.

⚠ DANGER *Danger indicates an imminently hazardous situation which, if NOT avoided, WILL result in death or serious injury.*

⚠ DANGER *La mention danger indique une situation dangereuse imminente qui, si elle n'est pas évitée, ENTRAÎNE la mort ou des blessures graves.*

⚠ WARNING *Warning indicates a potentially hazardous situation which, if NOT avoided, COULD result in death or serious injury.*

⚠ AVERTISSEMENT *La mention avertissement indique une situation potentiellement dangereuse qui, si elle n'est pas évitée, risque d'entraîner des lésions corporelles graves ou même la mort.*

⚠ CAUTION *Caution indicates a potentially hazardous situation which, if NOT avoided, MAY result in minor or moderate injury.*

⚠ MISE EN GARDE *La mention mise en garde indique une situation potentiellement dangereuse qui, si elle n'est pas évitée, pourrait entraîner des blessures mineures ou modérées.*

NOTICE *Notice indicates important information, that if NOT followed, MAY cause damage to equipment.*

GENERAL SAFETY INFORMATION

CALIFORNIA PROPOSITION 65

⚠ WARNING

This product can expose you to chemicals, including DEHP, which is known to the State of California to cause cancer, birth defects and reproductive harm. For more information, go to www.P65Warnings.ca.gov.

⚠ AVERTISSEMENT

Ce produit peut vous exposer à des produits chimiques, notamment du DOP, reconnus par l'État de Californie comme étant cancérigènes et à l'origine d'anomalies congénitales et de problèmes de l'appareil reproductif. Pour plus de renseignements, visiter le site www.P65Warnings.ca.gov.

⚠ WARNING

RISK OF ELECTRIC SHOCK. TO REDUCE THIS RISK, OBSERVE THE FOLLOWING WARNINGS:

⚠ AVERTISSEMENT

RISQUE DE CHOC ÉLECTRIQUE. POUR RÉDUIRE CE RISQUE, TENIR COMPTE DES AVERTISSEMENTS SUIVANTS :

MAKE SURE THERE IS A PROPERLY GROUNDED RECEPTACLE AVAILABLE. This pump is supplied with a grounding conductor and grounding-type attachment plug. To reduce the risk of electric shock, be certain that it is connected only to a properly grounded, grounding-type receptacle.

MAKE SURE THERE IS A PROPERLY GROUNDED RECEPTACLE AVAILABLE. This pump is supplied with a grounding conductor and grounding-type attachment plug. To reduce the risk of electric shock, be certain that it is connected only to a properly grounded, grounding-type receptacle.

FOR ADDED SAFETY the receptacle must be protected with a ground fault circuit interrupter (GFCI). All wiring must be performed by a qualified licensed electrician and comply with the National Electric Code and all applicable local codes and ordinances.

POUR PLUS DE SÉCURITÉ, la prise de courant doit être protégée par un disjoncteur de fuite à la terre. Tout le câblage doit être effectué par un électricien qualifié et être conforme au Code électrique national et à tous les codes et règlements locaux applicables.

REMINDER: Keep your dated proof of purchase for warranty purposes! Attach it to this manual or file it for safekeeping.

GENERAL SAFETY INFORMATION (CONT'D)

NEVER REMOVE THE GROUND PRONG from the plug or bypass the grounding wires.

NE JAMAIS RETIRER LE CONNECTEUR DE MISE À LA TERRE de la prise ou contourner les fils de mise à la terre.

MAKE SURE THE POWER SUPPLY HAS A FUSE OR CIRCUIT BREAKER rated to handle the current (amps) noted on the pump nameplate or cordtag.

S'ASSURER QUE L'ALIMENTATION ÉLECTRIQUE EST MUNIE D'UN FUSIBLE OU D'UN DISJONCTEUR d'une valeur nominale appropriée pour supporter l'intensité du courant (ampérage) indiquée sur la plaque signalétique ou l'étiquette du cordon de la pompe.

ALWAYS DISCONNECT THE PUMP FROM power supply before installing, servicing or making any adjustments.

TOUJOURS METTRE LA POMPE HORS TENSION avant de procéder à l'installation, à l'entretien ou à des réglages.

DO NOT WALK on the floor when water is present until all power is turned off. If the electric panel is in the basement, call an electrician.

NE PAS MARCHER sur un sol mouillé avant que l'alimentation générale ne soit coupée. Si le tableau électrique est en sous-sol, appeler un électricien.

NEVER HANDLE A PUMP or motor with wet hands or when standing on a wet or damp floor while the pump is plugged into the power supply.

NE JAMAIS MANIPULER UNE POMPE ou un moteur de pompe avec les mains mouillées ou debout dans l'eau ou sur une surface humide.

RISK OF ELECTRIC SHOCK. This pump has not been investigated for use in swimming pool and marine areas.

RISQUE DE CHOC ÉLECTRIQUE. Cette pompe n'a pas fait l'objet de vérification pour une utilisation dans les piscines et les aires marines.

DO NOT USE TO PUMP FLAMMABLE OR EXPLOSIVE FLUIDS such as gasoline, fuel oil, kerosene, etc. Do not use in a flammable and/or explosive atmosphere. Pump should only be used to pump clear water. Personal injury and/or property damage could result and void warranty.

NE PAS UTILISER POUR POMPER DES FLUIDES INFLAMMABLES OU EXPLOSIFS tels que l'essence, le mazout, le kérosène, etc. Ne pas utiliser dans un environnement inflammable et/ou explosif. La pompe ne doit être utilisée que pour pomper de l'eau claire. Des blessures corporelles et/ou des dégâts matériels pourraient en résulter.

PUMPS ARE NOT DESIGNED TO TRANSFER WATER INTENDED FOR DRINKING. Do not use the pump for moving water that will be used for portable/drinking water. Pump should only be used in applications for which it is designed.

LES POMPES NE SONT PAS CONÇUES POUR L'ACHEMINEMENT D'EAU DESTINÉE À LA CONSOMMATION. Ne pas utiliser la pompe pour transporter de l'eau qui sera utilisée comme de l'eau potable/destinée à la consommation. La pompe doit être utilisée uniquement dans les applications pour lesquelles elle est conçue.

⚠ WARNING

DO NOT USE AN EXTENSION CORD OR SURGE PROTECTOR. Extension cords and/or surge protectors could present a safety hazard if not sized properly, become damaged or the connection falls into the water. If receptacle is not within reach of the pump's power cord, contact a qualified licensed electrician to install a new receptacle.

⚠ AVERTISSEMENT

NE PAS UTILISER DE RALLONGE NI DE PROTECTEUR DE SURTENSION. Les rallonges et/ou les protecteurs de surtension peuvent présenter un danger pour la sécurité s'ils ne sont pas correctement calibrés, s'ils sont endommagés ou si le raccordement tombe dans le puisard. Si la prise n'est pas à portée du cordon d'alimentation de la pompe, contacter un électricien qualifié pour installer une nouvelle prise.

⚠ CAUTION TO REDUCE THE RISK OF HAZARDS THAT CAN CAUSE INJURY OR PROPERTY DAMAGE, OBSERVE THE FOLLOWING WARNINGS:

⚠ MISE EN GARDE POUR RÉDUIRE LE RISQUE DE DANGERS POUVANT CAUSER DES BLESSURES OU DES DÉGÂTS MATÉRIELS, RESPECTER LES MISES EN GARDE SUIVANTES :



DO NOT INSTALL OR OPERATE THE PUMP IF IT HAS BEEN DAMAGED IN ANY WAY.

NE PAS INSTALLER OU FAIRE FONCTIONNER LA POMPE SI ELLE A ÉTÉ ENDOMMAGÉE DE QUELQUE MANIÈRE QUE CE SOIT.

DO NOT USE THIS PUMP IN MUD, SAND, CEMENT, OIL CHEMICALS, GREY WATER, OR ANY OTHER WATER THAT IS NOT CONDENSATE GROUND WATER.

NE PAS UTILISER CETTE POMPE DANS LA BOUE, LE SABLE, LE CIMENT, LES PRODUITS CHIMIQUES À L'HUILE, DE L'EAU GRISÂTRE OU TOUTE AUTRE EAU QUI N'EST PAS DE L'EAU CLAIRE SOUTERRAINE.

Operating Instructions and Parts Manual

GENERAL SAFETY INFORMATION (CONT'D)

1. Know the pump application, limitations, and potential hazards.
2. Make certain that the power supply conforms to the requirements of the unit.

Personal Safety:

- a. Wear safety glasses at all times when working with pumps.
- b. Keep work area clean, uncluttered and properly lighted; replace all unused tools and equipment.
- c. Keep visitors a safe distance from the work area.



⚠ WARNING Risk of electric shock! Never connect either auxiliary white wire to line voltage. Both white wires are for connection to an HVAC only. See page 6, figure 5.

⚠ AVERTISSEMENT Risque de choc électrique! Ne connectez jamais auxiliaire de fil blanc de la tension de ligne. Les deux fils blancs sont pour la connexion à un CVC. Voir la page 6, la figure 5.

INSTALLATION

STEP 1: INSTALLATION OF PIPE

- A. Insert the discharge pipe or pipe nipple into the 3/8" ID plastic tube.

⚠ CAUTION Before removing pump from its mounting position for service, always disconnect electrical power to pump and control switch. For any work on pump or switch, always unplug the power cord. Do not just turn off circuit breaker or unscrew fuse.

⚠ MISE EN GARDE Avant de retirer la pompe de sa position de montage pour réparation, toujours couper le courant à la pompe et à l'interrupteur. Pour tout travail sur la pompe ou sur l'interrupteur, toujours débrancher le cordon d'alimentation. Ne pas simplement éteindre le disjoncteur ou dévisser le fusible.

STEP 2: MOUNTING CONDENSATE UNIT

- A. Position the pump below the evaporator drain and/or furnace drain.
- B. The pump can be installed to the wall or side of the appliance using the two mounting brackets. Refer to Figure 1.

STEP 3: INSTALLATION OF CONDENSATE DRAIN LINES

- A. To prevent pipe blockage in the reservoir, modify the end of pipe or tubing as illustrated in Figure 2.
- B. Plumb flexible tube or pipe from the condensate drain, and from the furnace drain (if applicable), to the inlet holes on the pump. Refer to Figure 3.

STEP 4: INSTALLATION OF DISCHARGE LINE

NOTE: Use 3/8" I.D. (max.) flexible tubing. A hose clamp is recommended (not provided).

- A. Extend discharge pipe from barbed check valve to the highest point possible. Refer to Figure 4.
- B. From this point, direct the discharge line to the location of the drainage source. Maintain a continuous downward slope.

NOTE: Construct an inverted "U" (see Figure 4) at the highest point of discharge line if a continuous downward slope is not possible. Exercise care not to kink or "pinch off" the flow of condensate liquid.

STEP 5: INSTALLATION OF SAFETY SWITCH (IF APPLICABLE)

⚠ CAUTION Safety switch is only to be used on Class 2 circuit, 30V AC, 3.2 amps maximum.

⚠ MISE EN GARDE L'interrupteur de sécurité ne doit être utilisé que sur un circuit de classe 2, 30 volts de c.a., 3,2 ampères maximum.

NOTICE Connect power cord to a constant voltage source. Do not connect to a fan or other device that may run intermittently.

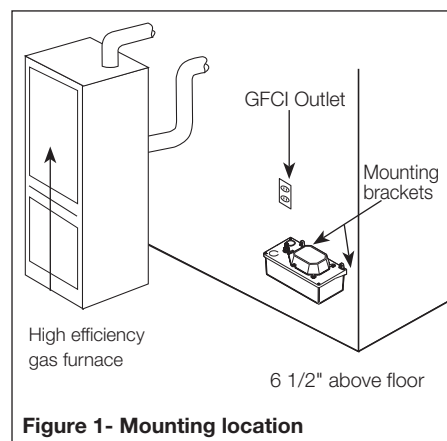

Figure 1 - Mounting location

- A. The pump can be wired directly to the appliance thermostat to shut the appliance down in the event of pump failure. Refer to Figure 5 for typical wiring diagram.

NOTE: The alarm can be wired in the safety switch at the normally open ("NO") contact.

TIPS FOR EASY INSTALLATION

1. After reading instructions, check to make sure installation does not exceed a maximum of 15 feet of vertical lift.
2. Make sure pump is level. No part of the pump base should be more than 1/8" off of level plane.
3. Use soapy water on unit when performing cleaning maintenance (refer to Maintenance guidelines).

INSTALLATION (CONT'D)

4. For optimum performance, drain and discharge lines should have a continuous downward slope. Test operation of pump to make sure lines have enough downward slope for efficient operation.
5. Avoid overtightening of check valve after cleaning (refer to Maintenance guidelines).
6. To assure proper performance, the highest point of discharge line should be higher than 5' off the floor.
7. Clean any debris in the pump reservoir if necessary.
8. Do not handle the pump until you have disconnected it from the power source.
9. Do not use a pump discharge pipe smaller than the pump discharge size.
10. After installation, test pump to make sure that system is working properly.
11. Make sure that installation conforms to all local and national codes.
12. Local codes may require the use of a condensate neutralizer when using this pump (refer to Figure 3).

1. Release all pressure within the system before servicing any component.
2. Drain all liquids from the system before servicing.
3. Secure the discharge line before starting the pump. An unsecured discharge line will whip, possibly causing personal injury and/or property damage.

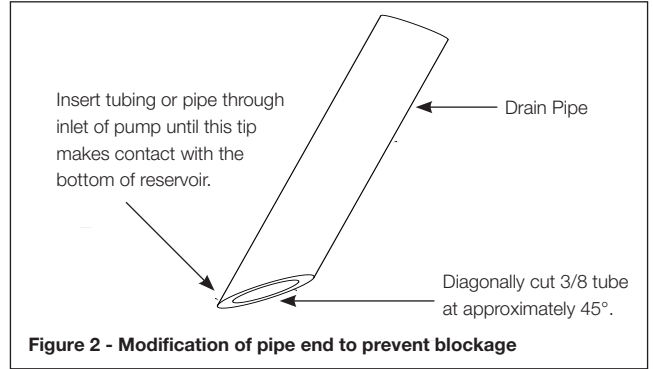

Figure 2 - Modification of pipe end to prevent blockage

MAINTENANCE

⚠ WARNING *Make certain that the pump is unplugged before attempting to service or remove any component. This pump is assembled in the factory using special equipment; therefore only authorized service dealers or qualified electricians should attempt to repair the unit. Improper repair can cause an electrical shock hazard, and void warranty.*



⚠ AVERTISSEMENT *Toujours s'assurer que la pompe est débranchée avant de procéder à un entretien, une réparation ou de retirer un composant. Cette pompe est assemblée en usine utilisant de l'équipement spécial, par conséquent seuls des concessionnaires ou des électriciens qualifiés peuvent essayer de réparer cet appareil. Une réparation inadéquate peut provoquer un risque de choc électrique et annuler la garantie.*

⚠ DANGER *Disconnect power before servicing. If the power disconnect is out of sight, lock in the open position and tag it out to prevent unexpected application of power. Failure to do so could result in fatal electrical shock.*

⚠ DANGER *Débrancher l'alimentation avant de procéder à l'entretien. Si la source de courant n'est pas visible, verrouiller en position ouverte et étiqueter pour éviter tout rétablissement inattendu du courant. Le non-respect de ces instructions pourrait mener à un choc électrique mortel.*

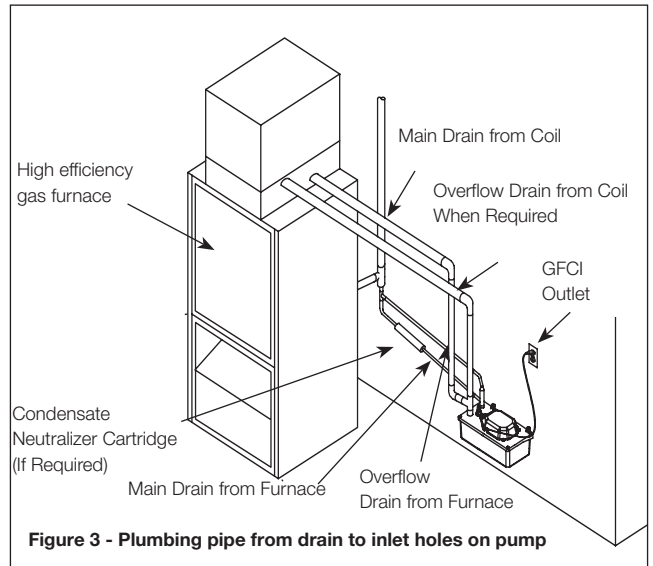

Figure 3 - Plumbing pipe from drain to inlet holes on pump

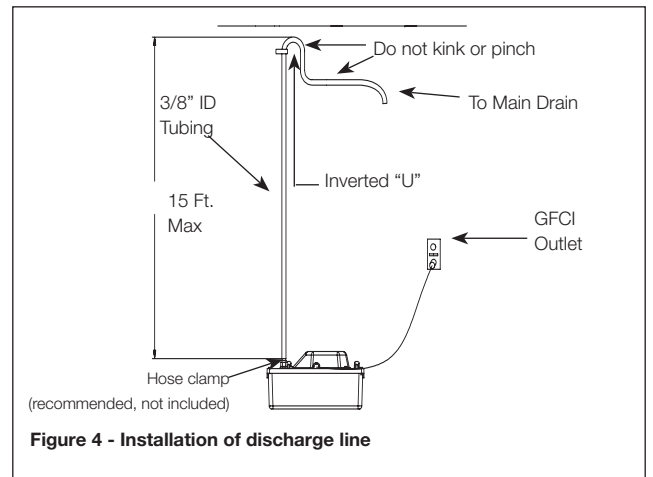

Figure 4 - Installation of discharge line

Operating Instructions and Parts Manual

MAINTENANCE (CON'T)

4. Check hoses for weak and worn condition before seasonally, making certain that all connections are secure.
5. Periodically inspect the pump and system components. Perform routine maintenance as required.

CLEANING RESERVOIR AND IMPELLER

1. Unscrew two screws through mounting brackets, and remove pump from wall, if mounted.
2. Remove reservoir from deck by unscrewing the four screws located at the corners of the reservoir cover.
3. Use a damp cloth to clean reservoir.
4. Then reassemble reservoir to reservoir cover.

CLEANING CHECK VALVE

1. Disconnect discharge line from check valve – see Figure 6.
2. Remove check valve with 9/16" wrench.
3. Visually check for obstructions or damage.
4. If check valve is not damaged, replace valve by hand-tightening. Then tighten a half turn with 9/16" wrench.

NOTICE Do not overtighten. Damage to O-ring seal may occur, and will void warranty.

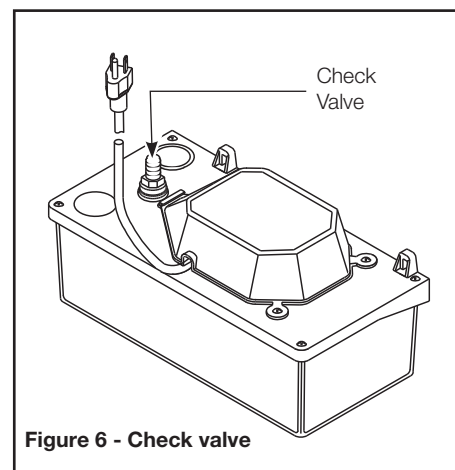
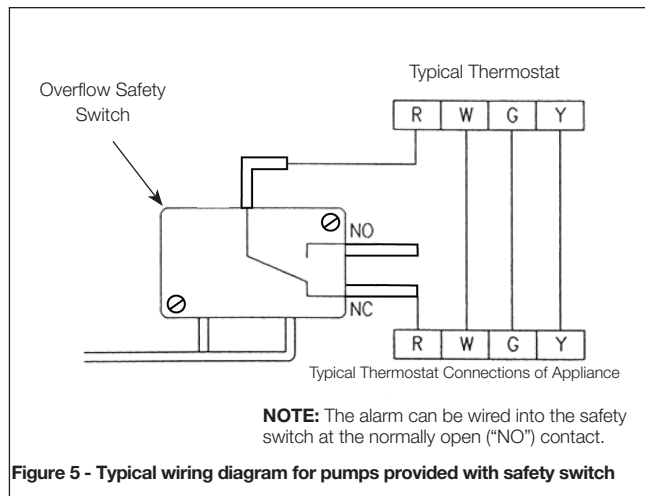

TROUBLESHOOTING CHART

⚠ CAUTION

Pump may start unexpectedly. Disconnect power supply before servicing.

⚠ MISE EN GARDE

La pompe peut démarrer de façon inattendue. Débrancher l'alimentation électrique avant l'entretien.

Symptoms	Possible Cause(s)	Suggested Remedies
Pump fails to run	<ol style="list-style-type: none"> 1. Pump not plugged in 2. Low voltage, blown fuse, open circuit 3. Reservoir is absent of condensate 4. Drain/discharge lines blocked 	<ol style="list-style-type: none"> 1. Plug in 2. Have a certified electrician check fuse circuit 3. Check drain line and/or discharge line for obstructions 4. Check drain lines and/or discharge line for obstructions
Pump emits loud noise when operating	<ol style="list-style-type: none"> 1. Foreign material in reservoir 	<ol style="list-style-type: none"> 1. Refer to Maintenance section for cleaning instructions
Pump operates but there is no flow of liquid	<ol style="list-style-type: none"> 1. Float is sticking 2. Discharge height greater than 15 ft. 3. Obstruction in discharge pipe 4. Blockage in check valve 5. Damaged check valve 	<ol style="list-style-type: none"> 1. Refer to Maintenance section for cleaning instructions 2. Refer to Figure 4 for proper installation 3. Check discharge line for blockage. Remove any debris 4. Refer to Maintenance section for cleaning instructions 5. Contact WAYNE Customer Support
Liquid drains back into pump from discharge line	<ol style="list-style-type: none"> 1. Damaged check valve 2. Blockage in check valve 3. Discharge line is 5 ft. or less 	<ol style="list-style-type: none"> 1. Contact WAYNE Customer Support 2. Refer to Maintenance section for cleaning instructions 3. Condensate liquid may drain out of line into reservoir due to discharge height. This is normal. No action is necessary
Liquid leaks from around check valve	<ol style="list-style-type: none"> 1. Check valve fastened too tight or to loose 2. Damage to O-ring 	<ol style="list-style-type: none"> 1. Check valve should be hand tightened then tightened an additional half turn with a 9/16 in. wrench. 2. Replace with a 1/2 in. ID. x 11/16 in. OD x 3/32 in. thick O-ring or contact WAYNE Customer Support at 800-237-0987

⚠ WARNING

Before servicing a pump, always shut off the main power breaker and then unplug the pump. Make sure you are not standing in water. Make sure you are wearing insulated, protective soled shoes. Under flooded conditions, check your local electric company or a qualified licensed electrician for disconnecting electrical service prior to pump removal. If the above checklist does not solve the problem, contact WAYNE Customer Support at 1-800-237-0987.

⚠ AVERTISSEMENT

Avant tout entretien ou réparation de pompe, toujours couper le courant au disjoncteur, puis débrancher la pompe. S'assurer de ne pas rester debout dans l'eau et porter des chaussures à semelles de protection isolées. En cas d'inondation, vérifier auprès de la société locale d'électricité ou d'un électricien agréé qualifié pour couper le service électrique avant le retrait de la pompe. Si la liste de vérification ci-dessus ne permet pas de résoudre le problème, contacter le service clientèle de WAYNE au 1-800-237-0987.



LIMITED WARRANTY

For one year for WCP85 model from the date of purchase, from an authorized dealer, Wayne Water Systems will repair or replace, at its option for the original purchaser, any part or parts of its Multi-Use Pumps or Water Pumps ("Product") found upon examination by Wayne Water Systems to be defective in materials or workmanship. Please call Wayne Water Systems (800-237-0987) for warranty instructions. Be prepared to provide the model number and the serial number when exercising this warranty. All transportation charges on Products or parts submitted for repair or replacement must be paid by purchaser.

This Limited Warranty does not cover Products which have been damaged as a result of accident, abuse, misuse, neglect, improper installation, improper maintenance, or failure to operate in accordance with Wayne Water Systems' written instructions.

THIS WARRANTY IS IN LIEU OF ANY AND ALL OTHER WARRANTIES, OBLIGATIONS OR AGREEMENTS, EXPRESSED OR IMPLIED, INCLUDING ANY IMPLIED WARRANTY OF MERCHANTABILITY OR FITNESS FOR ANY PARTICULAR PURPOSE, AND ANY RIGHTS OR REMEDIES AGAINST ANY PERSON OR ENTITY UNDER THE UNIFORM COMMERCIAL CODE OR OTHERWISE WITH RESPECT TO THE SALE OF THE PRODUCT. THE REMEDIES AND OBLIGATIONS STATED IN THIS WARRANTY ARE THE SOLE AND EXCLUSIVE REMEDIES OF AND OBLIGATIONS TO THE OWNER FOR ANY AND ALL MATTERS ARISING WITH RESPECT TO OR IN ANY WAY CONNECTED WITH THE PRODUCT, REGARDLESS OF THE SOURCE OR PROVIDER OF SUCH GOODS. IN NO EVENT, WHETHER AS A RESULT OF BREACH OF CONTRACT, WARRANTY TORT (INCLUDING NEGLIGENCE) OR OTHERWISE, SHALL WAYNE WATER SYSTEMS OR ANY AFFILIATE BE LIABLE FOR ANY SPECIAL, INCIDENTAL OR CONSEQUENTIAL DAMAGES.

You **MUST** retain your purchase receipt along with this form. In the event you need to exercise a warranty claim, you **MUST** send a **copy** of the purchase receipt along with the material or correspondence. Please call Wayne Water Systems (800-237-0987) for return authorization and instructions.

DO NOT MAIL THIS FORM TO Wayne Water Systems. Use this form only to maintain your records.

MODEL NO. _____ SERIAL NO. _____ INSTALLATION DATE _____

ATTACH YOUR RECEIPT HERE